

BALLUFF

sensors worldwide

Ultrasonic Sensors BUS

...sound solutions for object detection and measurement

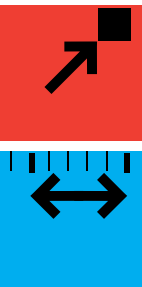

Ultrasonic Sensors

Introduction and applications

The best selection for rugged, high-performance feedback

Providing industrial solutions for your target detection, distance measurement, or fill level monitoring needs, BUS ultrasonic sensors from Balluff offer you a number of options for all types of target media, including solids, powders, and liquids.

Based on the latest in acoustic wave technology, BUS ultrasonic sensors detect objects with superior performance to many traditional sensor technologies because of their ability to see targets independent of color, transparency, and surface texture. Ultrasonic sensors show their true strength, however, when long sensing ranges and high accuracy are needed. In dusty, humid, or hazy environments, they are sometimes the only choice available.

Performance at a Glance

- Multiple sensing ranges available from short to long (up to 6 m, 19.7 ft)
- Tubular and block style housings for ease of mounting
- Rugged industrial IP65 or IP67 protection ratings
- Discrete, analog or combination output configuration options designed to work with industry-standard controllers and reduce your systems' device count
- Programmable setpoints and operating modes to provide you with enhanced functionality for critical applications



Object Detection

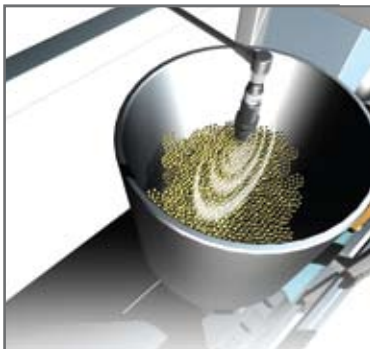

Efficiently monitor filling level



Verify stack heights



Reliably detect and count objects

Linear Measurement



Reliably measure distance



Optimally monitor foil sag



Precisely measure roll diameters

Ultrasonic Sensors

Object detection

Order Code	Part Number	Wiring Diagram	Sensing Range		Output Type				Teach-in Method			Features		
			Range		PNP	NPN	NO	NC	Potentiometer	Remote	Magnet	Window Mode	Sync	
M12x1														
BUS0005	BUS M12E0-PPXCR-020-S04G	3	25...200 mm		■			+	+		■		■	
BUS0006	BUS M12E0-NPXCR-020-S04G	4	25...200 mm			■		+	+		■		■	
41x26x12 mm														
BUS0007	BUS R05K0-PPXCR-025-S75G	3	25...250 mm		■			+	+		■	■	■	
BUS0008	BUS R05K0-NPXCR-025-S75G	4	25...250 mm			■		+	+		■	■	■	
M18x1														
BUS0001	BUS M18K0-PWXER-040-S92K	5	30...400 mm		■ ■			+	+		■		■	
BUS0002	BUS M18K0-NWXER-040-S92K	6	30...400 mm			■ ■		+	+		■		■	
BUS000T	BUS M18K0-PSXEP-030-EP00,3-GS92	1	60...300 mm		■					■				■
BUS000Y	BUS M18K0-NSXEP-030-EP00,3-GS92	2	60...300 mm			■				■				■
BUS000R	BUS M18K0-PSXEP-060-EP00,3-GS92	1	100...600 mm		■					■				■
BUS000W	BUS M18K0-NSXEP-060-EP00,3-GS92	2	100...600 mm			■				■				■
BUS000P	BUS M18K0-PSXEP-150-EP00,3-GS92	1	200...1500 mm		■					■				■
BUS000U	BUS M18K0-NSXEP-150-EP00,3-GS92	2	200...1500 mm			■				■				■
M30x1.5														
BUS000Z	BUS M30K0-PSXER-250-S04K	1	300...2500 mm		■					■				■
BUS0010	BUS M30K0-NSXER-250-S04K	2	300...2500 mm			■				■				■
80x80x50 mm														
BUS000A	BUS Q80K0-PWXER-600-S92K	5	600...6000 mm		■ ■			+	+		■		■	
BUS000C	BUS Q80K0-NWXER-600-S92K	6	600...6000 mm			■ ■		+	+		■		■	

■ ■ = Two PNP or NPN outputs
 + = Selectable



Common Specifications

Supply voltage	18...30 V DC
Reverse polarity protection	Yes
Short circuit protection	Yes
Ambient temperature range	-15...+70° C
Temperature compensation	Yes
Output function indicator	Yellow LED
Echo function indicator	Green LED
Degree of protection	IP67 (M18, M30, 46x12) IP65 (M12, 80x80)
Housing material	Stainless steel or PBT
Sensing face	Epoxy Resin/PUR
Sound cone opening angle	8 Degree

Wiring Diagrams

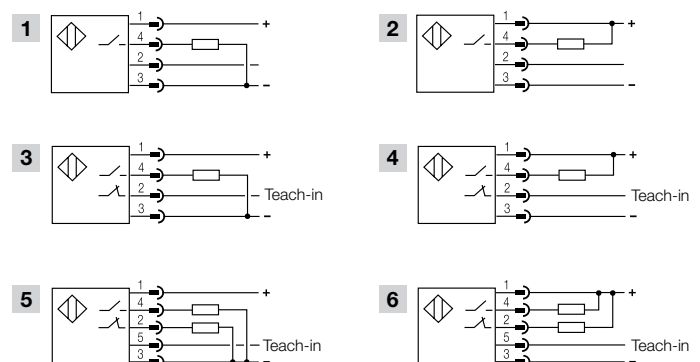

Ultrasonic Sensors

Linear measurement

Order code	Part Number		Sensing Range	Output				Slope		Teach-in Method			Features	
				Range	0...10 V	4...20 mA	PNP	NPN	Fixed	Adjustable	Remote	Button	Magnet	Window mode
41x26x12														
BUS0009	BUS R05K0-XACR-025-S75G	7	25...250 mm	■					■	■		■		
M18x1														
BUS0003	BUS M18K0-XAER-040-S92K	9	30...400 mm	■					■	■				
BUS0004	BUS M18K0-XBER-040-S92K	10	30...400 mm		■				■	■				
BUS000K	BUS M18K0-XAFX-030-S04K	7	60...300 mm	■				■						■
BUS000N	BUS M18K0-XBFX-030-S04K	8	60...300 mm		■			■						■
BUS000J	BUS M18K0-XAFX-060-S04K	7	100...600 mm	■				■						■
BUS000M	BUS M18K0-XBFX-060-S04K	8	100...600 mm		■			■						■
BUS000H	BUS M18K0-XAFX-150-S04K	7	200...500 mm	■				■						■
BUS000L	BUS M18K0-XBFX-150-S04K	8	200...1500 mm		■			■						■
M30x1.5														
BUS0016	BUS M30K0-PWCET-150-S92K	11	80...1600 mm	+	+	■	■		■	■	■			■
BUS0018	BUS M30K0-NWCET-150-S92K	12	80...1600 mm	+	+		■	■	■	■	■			■
BUS0015	BUS M30K0-PWCET-350-S92K	11	350...3500 mm	+	+	■	■		■	■	■			■
BUS0017	BUS M30K0-NWCET-350-S92K	12	350...3500 mm	+	+		■	■	■	■	■			■
80x80x50 mm														
BUS000E	BUS Q80K0-XAER-600-S92K	9	600...6000 mm	■					■	■				
BUS000F	BUS Q80K0-XBER-600-S92K	10	600...6000 mm		■				■	■				

■ ■ = Two PNP or NPN outputs
 + = Selectable



Wiring Diagrams

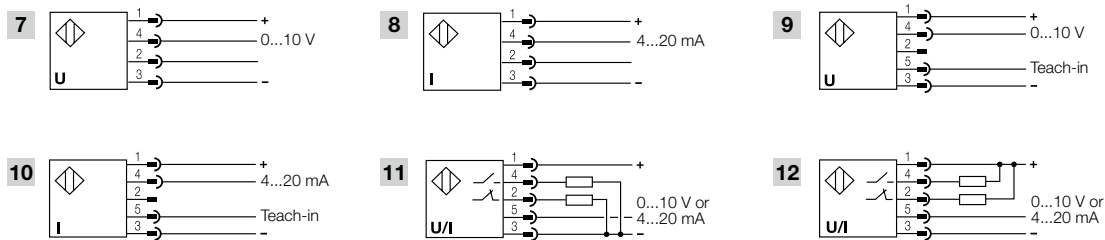

M12x1 41x26x12 mm M18x1 M18x1 (EP00.3 version) M30x1.5 80x80x50 mm

Ultrasonic Sensors

Functional principle and sensor basics

Functional Principle

Ultrasound technology consists of acoustic waves greater than 20 kHz which, unlike electromagnetic waves, can only propagate in matter. When transmitted against a solid body, the sound is reflected. The sensor receives the reflected sound waves as an echo, determining the distance and converting this value into an output signal.

Industrial applications operate with high-frequency ultrasound in excess of 80 kHz. At these high frequencies, bundled sound cones are created. Depending on the surface properties, shape, and direction, these sound cones are reflected to varying degrees. Lower-frequency ultrasound on the other hand, propagates spherically in all directions and therefore, is not suitable for industrial applications.

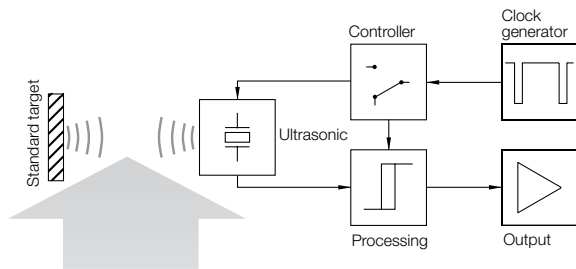

Sensor Basics

The range in which the sensor can detect objects is limited by the shortest and longest operating distance. This as well as the size of the blind zone, is determined by the size of the wave transducer. In the blind zone, the ultrasonic sensor cannot detect any objects. The zone is the result of the duration of the transmitted pulse and the release time of the ultrasonic transducer.

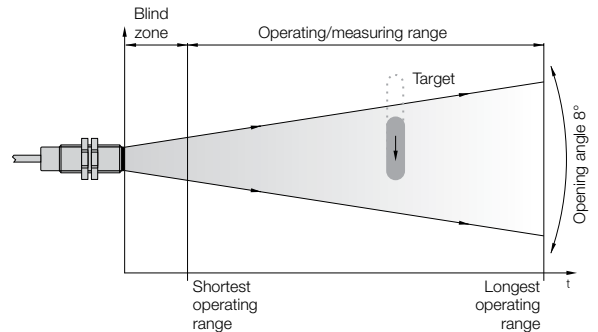

Object detection

Single or Dual Outputs

Standard discrete sensors come with one or two independently teachable outputs. Using either a potentiometer, a remote connection to ground, or applying a magnetic tipped pen to the sensor, each setpoint can be defined anywhere within the sensors' range.

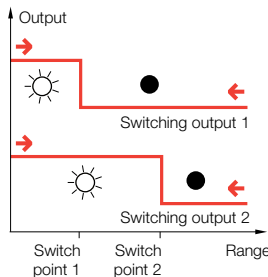

Window Mode

For select sensors with discrete outputs, a special function is available to create a sensing "window", where one of the outputs turns on only between setpoints 1 and 2. This feature is useful for positioning applications where the sensor output can help determine if a target is too close or too far from an ideal location.

Sync Input

On some models, an input is provided to prevent interference in applications where multiple ultrasonic sensors are used. The sync inputs are connected together, which causes the sensors to transmit their sound bursts simultaneously and eliminates any stray sound waves.



Analog distance measurement

Balluff BUS ultrasonic sensors for analog distance measurement are available with fixed slope, variable slope or variable slope with two evaluable switch points. In addition to the yellow LED, some sensors are also equipped with green LEDs, which serve as positioning aids.

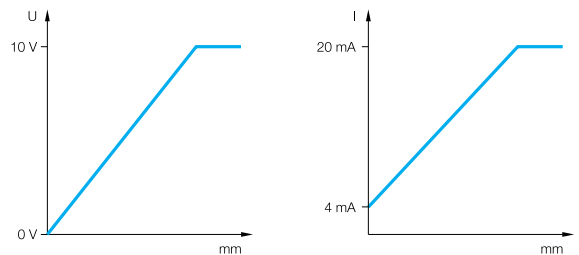

Fixed Slope

The minimum and maximum ranges of the sensor are fixed, and thus the slope of the analog output is also fixed.

Variable Slope

The working range of the analog output is defined by two teachable setpoints, which also defines the slope of the output. If SP1 is greater than SP2, the slope of the output is positive. If SP2 is greater than SP1, the slope of the output is negative.



Cables

Order Code	Straight	BCC0543	BCC05FJ	BCC01EK
Part Number		BCC M314-0000-10-003-VX44T2-050	BCC M415-0000-1A-003-VX44T2-050	C04 AEQ-00-VY-050M
Order Code	Right Angle	BCC059Y	BCC05TJ	BCC01JF
Part Number		BCC M324-0000-10-003-VX44T2-050	BCC M425-0000-1A-003-VX44T2-050	C04 BEQ-00-VY-050M
Number of Conductors		4	4	5
Connector		M8	M12	M12
Voltage Rating		60 VAC/VDC	250 VAC/VDC	250 VAC/VDC
Length		5m	5m	5m
LED		none	none	none
Cable Color		Yellow	Yellow	Yellow
Cable Material		PVC	PVC	PVC
Conductors		22 AWG	22 AWG	22 AWG
Sensor Connection Type		S75G	S04G, S04K	GS92, S92K

Sound deflection brackets and focusing attachments



Description	Sound deflection bracket for BUS M18	Sound deflection bracket for BUS M30	Focusing attachment M12 → 5 mm	Focusing attachment M18 → 11 mm
Ordering Code	BAM01EP	BAM01ER	BAM01ET	BAM01EU
Part Number	BAM BD-US-001-D20-4	BAM BD-US-001-D32-4	BAM AP-US-001-M12-0	BAM AP-US-002-M18-0
Material	V2A	V2A	POM	POM

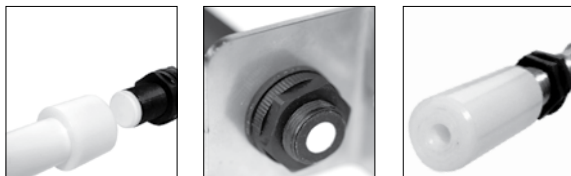

www.balluff.com/ultrasonic

USA
Balluff Inc.
8125 Holton Drive
Florence, KY 41042
Phone: (859) 727-2200
Toll-free: 1-800-543-8390
Fax: (859) 727-4823
E-Mail: balluff@balluff.com

Canada
Balluff Canada, Inc.
2840 Argenta Road, Unit #2
Mississauga, Ontario L5N 8G4
Phone: (905) 816-1494
Toll-free: 1-800-927-9654
Fax: (905) 816-1411
E-Mail: balluff.canada@balluff.ca

Mexico
Balluff de Mexico S.A. de C.V.
Prol. Av. Luis M. Vega #109
Col. Ampliación Cimatarío
Querétaro, QRO 76030
Phone: (+52 442) 212-4882, 224-3583, 224-3171
Fax: (+52 442) 214-0536
E-Mail: balluff.mexico@balluff.com



No. 183351 • Edition 10/2009 • 0824 • Product specifications, availability, and pricing are subject to change without notice.