

Analog Sensors BAW

... have a linear voltage or current output signal which changes in proportion to target distance from the damping surface. The curve is linear over the entire working range s .

- 1.7.2 Application examples, features, approach curve, processing programmable switch-points
- 1.7.3 M8
- 1.7.4 M12
- 1.7.6 M18
- 1.7.7 M18, M30
- 1.7.8 PG 36, Quadraform housing
- 1.7.9 Analog set point controller
- 1.7.10 M18 with 3 programmable switching outputs

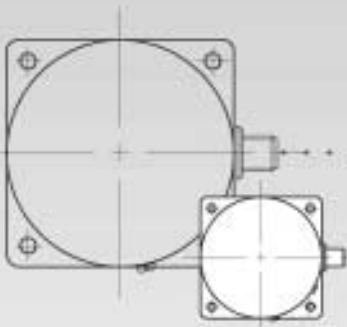
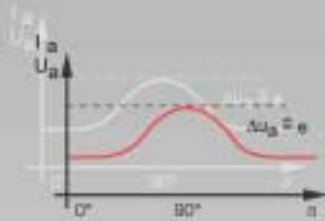
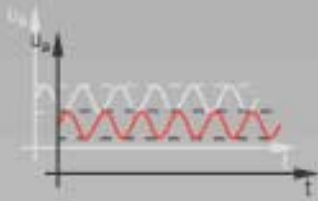

Application examples

Some of the numerous applications in measuring and controlling include:

- Distance measurement
- Thickness measurement
- Run-off measurement
- Belt/band width measurement
- Detection of surface waves
- Counting
- Positioning
- Position monitoring
- General monitoring
- Selection of parts of various sizes and materials

Features

- Distance-proportional analog signal
- Housing sizes M8...80x80
- Sensing ranges 1...50 mm
- Non-contact, absolute operating principle
- High repeat accuracy
- Low temperature drift
- LED for setup aid
- Compact, sealed, rugged and reliable

Axial approach

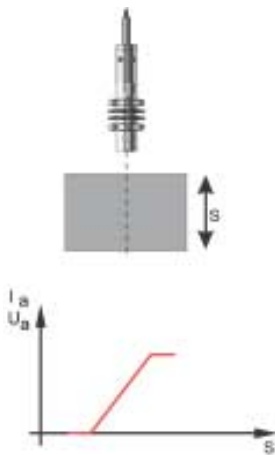

Distance changes in the sensor axis result in proportionally changing output signals.

Sensing a rotating object

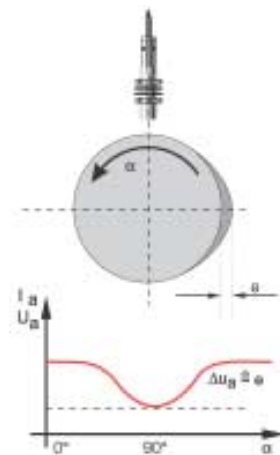

Eccentric cams, lobes or imbalances result in a periodic change of the output signal.

Lateral approach

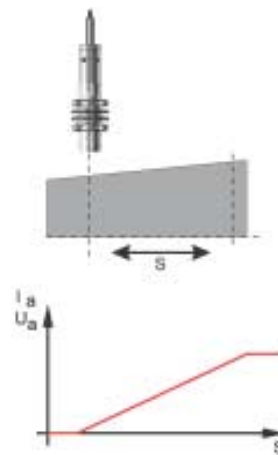

Detecting larger travel by sensing an inclined surface.

Sensing various materials

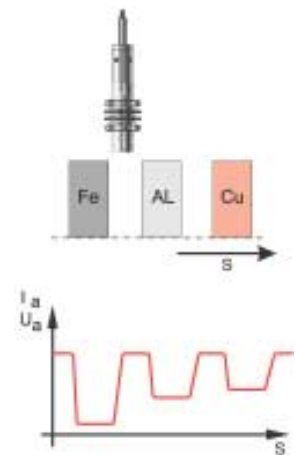

With the distance constant, the output signal will change only if the object material changes.

Approach curve

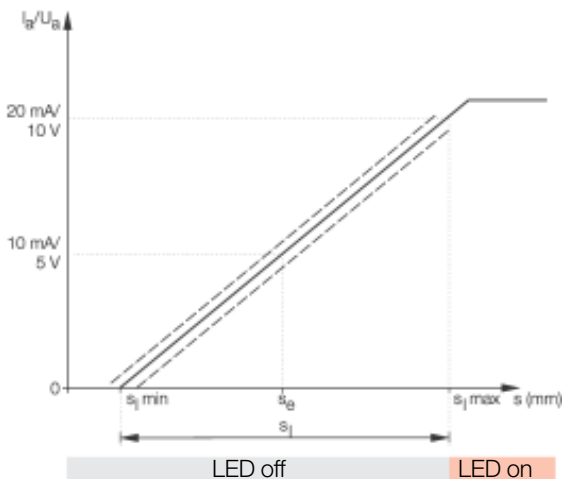

Processing programmable switchpoints

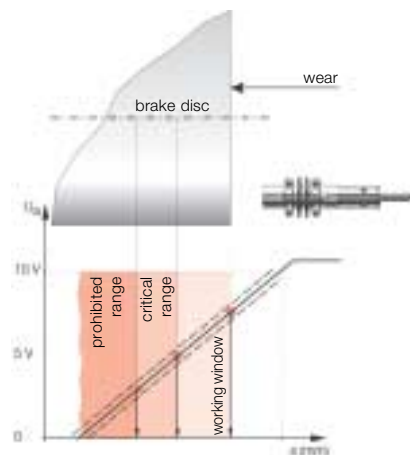

Housing size	M8x1	M8x1	
Mounting	flush	flush	
Output signal	voltage 0...10 V	voltage 0...10 V	
Linear range s_l	0.5...1.5 mm	0.5...1.5 mm	

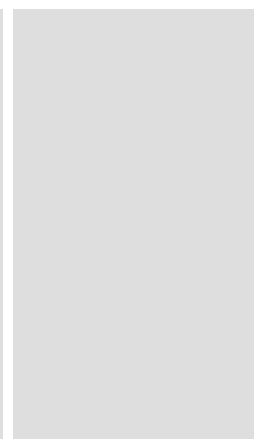
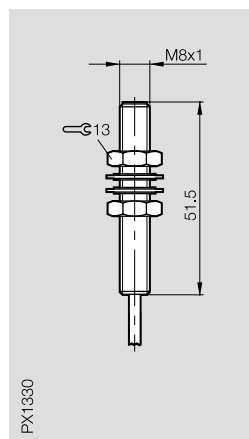
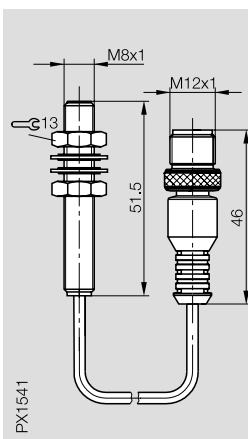

Ordering code	BAW M08EI-UAD15B-BP-___-GS04	BAW M08EI-UAD15B-	
Rated operational voltage U_e	24 V DC	24 V DC	
Supply voltage U_B	15...30 V DC	15...30 V DC	
Ripple	$\leq 15\%$ of U_e	$\leq 15\%$ of U_e	
Rated insulation voltage U_i	250 V AC	250 V AC	
Rated sensing distance s_e	1 mm	1 mm	
Load resistance R_l	$\geq 2\text{ k}\Omega$	$\geq 2\text{ k}\Omega$	
No-load supply current I_0 at U_e	$\leq 8\text{ mA}$	$\leq 8\text{ mA}$	
Protected against polarity reversal	yes	yes	
Short circuit protected	yes	yes	
Ambient temperature range T_a	-10...+70 °C	-10...+70 °C	
Temperature drift at s_l	$\leq 5\%$ of U_a max.	$\leq 5\%$ of U_a max.	
Max. non-linearity at s_l	$\pm 3\%$ of U_a max.	$\pm 3\%$ of U_a max.	
Adjustment indication (end of linear range)	no	no	
Degree of protection per IEC 60529	IP 67	IP 67	
Insulation class	□	□	
Housing material	stainless steel	stainless steel	
Material of sensing face	PBT	PBT	
Connection	cable with connector	cable	
No. of wires x conductor cross section		3 x 0.14 mm ²	
Approval	cULus	cULus	
Recommended connector	BKS-B 19		

Wiring diagrams



Please add the cable length to the ordering code for sensors with **cable!**
BP03, BP05 = PUR, length 3 m or 5 m

Please add the cable length to the ordering code for sensors with **cable and connector!**
00,2, 00,5 = PUR, length 0.2 or 0.5 m



Analog Sensors M12

Housing size	M12x1	M12x1	M12x1	M12x1
Mounting	flush	flush	flush	flush
Output signal	voltage 0...10 V	voltage 0...10 V	voltage 0...10 V	current 0...20 mA
Linear range s _i	0.5...2 mm	0.5...2 mm	0.5...2 mm	0.5...2 mm

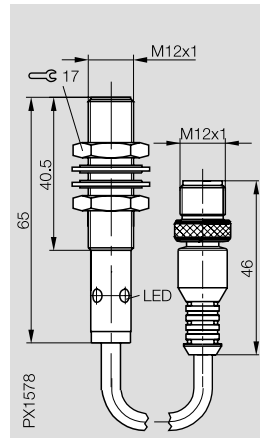
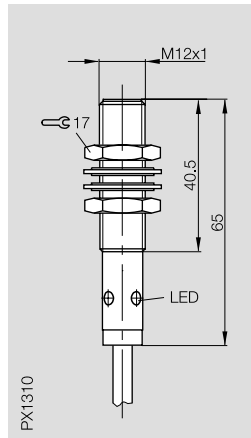
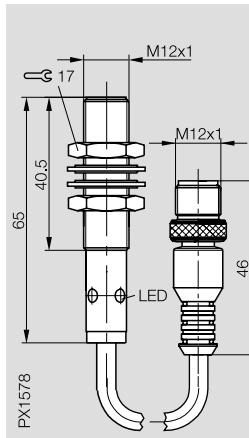
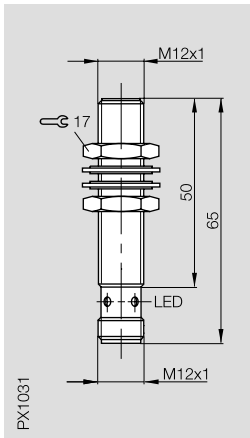

Ordering code	BAW M12MI-UAC20B-S04G	BAW M12MG2-UAC20B-BP___-GS04	BAW M12MG2-UAC20B-	BAW M12MG2-IAC20B-BP___-GS04
---------------	-----------------------	------------------------------	--------------------	------------------------------

Rated operational voltage U _e	24 V DC	24 V DC	24 V DC	24 V DC
Supply voltage U _B	15...30 V DC	15...30 V DC	15...30 V DC	10...30 V DC
Ripple	≤ 15 % of U _e	≤ 15 % of U _e	≤ 15 % of U _e	≤ 15 % of U _e
Rated insulation voltage U _i	250 V AC	250 V AC	250 V AC	250 V AC
Rated sensing distance s _e	1.25 mm	1.25 mm	1.25 mm	1.25 mm
Load resistance R _L	≥ 2 kΩ	≥ 2 kΩ	≥ 2 kΩ	≤ 0.5 kΩ
No-load supply current I ₀ at U _e	≤ 10 mA	≤ 10 mA	≤ 10 mA	≤ 10 mA
Protected against polarity reversal	yes	yes	yes	yes
Short circuit protected	yes	yes	yes	yes

Ambient temperature range T _a	-10...+70 °C	-10...+70 °C	-10...+70 °C	-10...+75 °C
Temperature drift at s _i	≤ 5 % of U _a max.	≤ 5 % of U _a max.	≤ 5 % of U _a max.	≤ 5 % of I _a max.
Max. non-linearity at s _i	±3 % of U _a max.	±3 % of U _a max.	±3 % of U _a max.	±3 % of I _a max.
Adjustment indication (end of linear range)	yes	yes	yes	yes

Degree of protection per IEC 60529	IP 67	IP 67	IP 67	IP 67
Insulation class	□	□	□	□
Housing material	CuZn nickel plated	CuZn nickel plated	CuZn nickel plated	CuZn nickel plated
Material of sensing face	PA 12	PA 12	PA 12	PA 12
Connection	connector	cable with connector	cable	cable with connector
No. of wires × conductor cross section			3 × 0.34 mm ²	
Approval	cULus	cULus	cULus	cULus
Recommended connector	BKS-B 19/BKS-B 20	BKS-B 19		BKS-B 19

Wiring diagrams

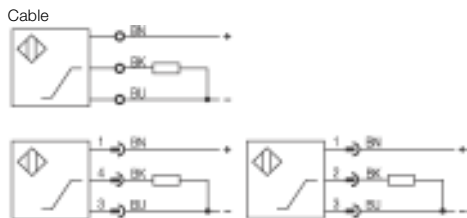

Please add the cable length to the ordering code for sensors with **cable!**
BP03, BP05 = PUR, length 3 m or 5 m

Please add the cable length to the ordering code for sensors with **cable and connector!**
00,2, 00,5 = PUR, length 0.2 or 0.5 m



M12x1
flush
current 0...20 mA
0.5...2 mm

M12x1
non-flush
voltage 0...10 V
1...4 mm

M12x1
non-flush
voltage 0...10 V
1...4 mm

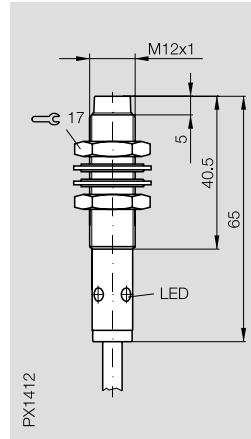
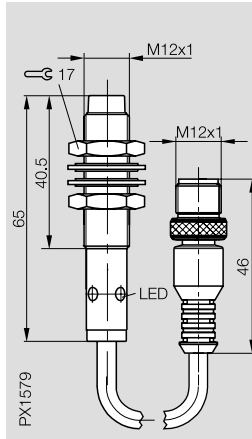
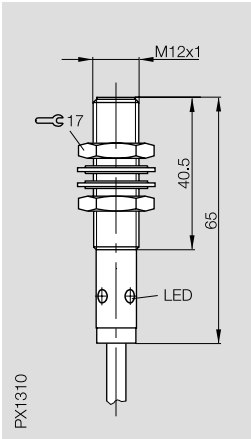

BAW M12MG2-IAC20B-

BAW M12MF2-UAC40F-BP-_-GSD4

BAW M12MF2-UAC40F-

24 V DC
10...30 V DC
 $\leq 15\%$ of U_e
250 V AC
1.25 mm
 $\leq 0.5\text{ k}\Omega$
 $\leq 10\text{ mA}$
yes
yes

24 V DC
15...30 V DC
 $\leq 15\%$ of U_e
250 V AC
2.5 mm
 $\geq 2\text{ k}\Omega$
 $\leq 10\text{ mA}$
yes
yes

24 V DC
15...30 V DC
 $\leq 15\%$ of U_e
250 V AC
2.5 mm
 $\geq 2\text{ k}\Omega$
 $\leq 10\text{ mA}$
yes
yes

-10...+70 °C
 $\leq 5\%$ of I_a max.
 $\pm 3\%$ of I_a max.
yes

-10...+70 °C
 $\leq 5\%$ of U_a max.
 $\pm 3\%$ of U_a max.
yes

-10...+70 °C
 $\leq 5\%$ of U_a max.
 $\pm 3\%$ of U_a max.
yes

IP 67

CuZn nickel plated
PA 12
cable
 $3 \times 0.34\text{ mm}^2$
cULus

IP 67

CuZn nickel plated
PBT
cable with connector
cULus
BKS-B 19

IP 67

CuZn nickel plated
PBT
cable
 $3 \times 0.34\text{ mm}^2$
cULus

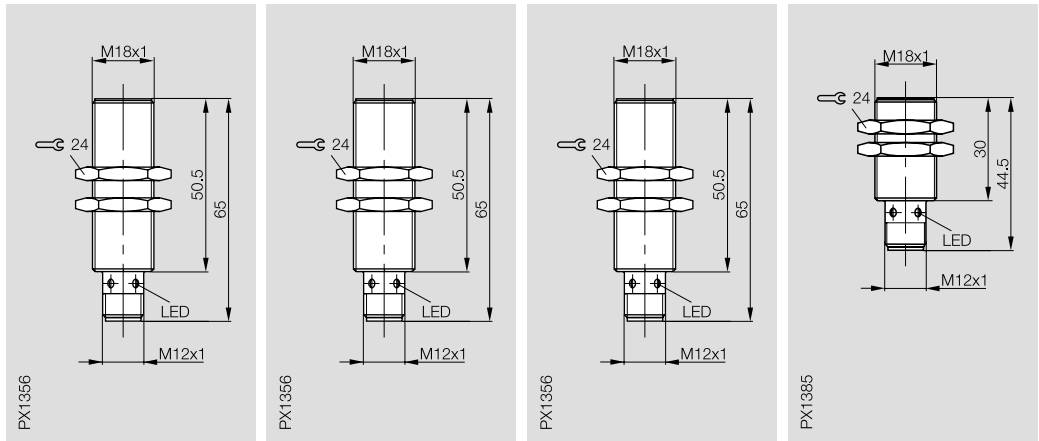

Analog Sensors M18

Housing size	M18x1	M18x1	M18x1	M18x1
Mounting	flush	flush	flush	flush
Output signal	voltage 0...10 V	current 0...20 mA	current 4...20 mA	voltage 0...10 V
Linear range s _i	1...5 mm	1...5 mm	1...5 mm	1...5 mm



Ordering code	BAW M18MI-UAC50B-S04G	BAW M18MI-IAC50B-S04G	BAW M18MI-ICC50B-S04G	BAW M18ME-UAC50B-S04G
Rated operational voltage U _e	24 V DC	24 V DC	24 V DC	24 V DC
Supply voltage U _B	15...30 V DC	10...30 V DC	10...30 V DC	15...30 V DC
Ripple	≤ 15 % of U _e	≤ 15 % of U _e	≤ 15 % of U _e	≤ 15 % of U _e
Rated insulation voltage U _i	250 V AC	250 V AC	250 V AC	75 V DC
Rated sensing distance s _e	3 mm	3 mm	3 mm	3 mm
Load resistance R _L	≥ 2 kΩ	≤ 0.5 kΩ	≤ 0.5 kΩ	≥ 2 kΩ
No-load supply current I ₀ at U _e	≤ 10 mA	≤ 10 mA	≤ 10 mA	≤ 10 mA
Protected against polarity reversal	yes	yes	yes	yes
Short circuit protected	yes	yes	yes	yes
Ambient temperature range T _a	-10...+70 °C	-10...+70 °C	-10...+70 °C	-10...+70 °C
Temperature drift at s _i	≤ 5 % of U _a max.	≤ 5 % of I _a max.	≤ 5 % of I _a max.	≤ 5 % of U _a max.
Max. non-linearity at s _i	±3 % of U _a max.	±3 % of I _a max.	±3 % of I _a max.	±3 % of U _a max.
Adjustment indication (end of linear range)	yes	yes	yes	yes
Degree of protection per IEC 60529	IP 67	IP 67	IP 67	IP 67
Insulation class	□	□	□	□
Housing material	CuZn nickel plated	CuZn nickel plated	CuZn nickel plated	CuZn nickel plated
Material of sensing face	PBT	PBT	PBT	PBT
Connection	connector	connector	connector	connector
No. of wires × conductor cross section				
Approval	cULus	cULus	cULus	cULus
Recommended connector	BKS-B 19/BKS-B 20	BKS-B 19/BKS-B 20	BKS-B 19/BKS-B 20	BKS-B 19/BKS-B 20

Wiring diagrams



Please add the cable length to the ordering code for sensors with **cable!**
 BP03, BP05 = PUR, length 3 m or 5 m

Please add the cable length to the ordering code for sensors with **cable and connector!**
 00,2, 00,5 = PUR, length 0.2 or 0.5 m



M18x1
flush
voltage 0...10 V
1...5 mm

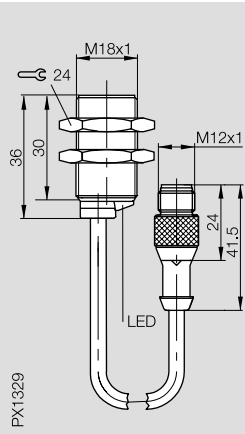

M18x1
flush
voltage 0...10 V
1...5 mm

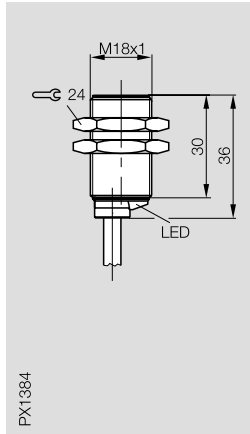

M18x1
non-flush
voltage 0...10 V
2...8 mm

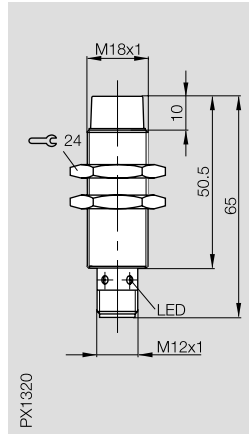

M30x1
flush
voltage 0...10 V
2...10 mm

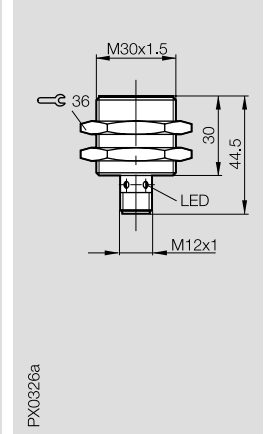

BAW M18ME-UAC50B-BP_..._GS04

BAW M18ME-UAC50B-

BAW M18MG-UAC80F-S04G

BAW M30ME-UAC10B-S04G

24 V DC
15...30 V DC
 $\leq 15\%$ of U_e
75 V DC
3 mm
 $\geq 2\text{ k}\Omega$
 $\leq 10\text{ mA}$
yes
yes

24 V DC
15...30 V DC
 $\leq 15\%$ of U_e
75 V DC
3 mm
 $\geq 2\text{ k}\Omega$
 $\leq 10\text{ mA}$
yes
yes

24 V DC
15...30 V DC
 $\leq 15\%$ of U_e
250 V AC
5 mm
 $\geq 2\text{ k}\Omega$
 $\leq 10\text{ mA}$
yes
yes

24 V DC
15...30 V DC
 $\leq 15\%$ of U_e
250 V AC
6 mm
 $2\text{ k}\Omega$
 $\leq 10\text{ mA}$
yes
yes

-10...+70 °C
 $\leq 5\%$ of $U_a\text{ max.}$
 $\pm 3\%$ of $U_a\text{ max.}$
yes

-10...+70 °C
 $\leq 5\%$ of $U_a\text{ max.}$
 $\pm 3\%$ of $U_a\text{ max.}$
yes

-10...+70 °C
 $\leq 5\%$ of $U_a\text{ max.}$
 $\pm 3\%$ of $U_a\text{ max.}$
yes

-10...+70 °C
 $\leq 5\%$ of $U_a\text{ max.}$
 $\pm 3\%$ of $U_a\text{ max.}$
yes

IP 67
CuZn nickel plated
PBT
cable with connector

IP 67
CuZn nickel plated
PBT
cable
 $3 \times 0.34\text{ mm}^2$

IP 67

CuZn nickel plated
PBT
connector

IP 67

CuZn nickel plated
PBT
connector

cULus
BKS-B 19

cULus

cULus
BKS-B 19/BKS-B 20

cULus
BKS-B 19/BKS-B 20



Analog Sensors PG 36, Quadraform Housing

Housing size	PG 36	80x80x40
Mounting	flush	non-flush
Output signal	voltage 0...10 V	voltage 0...10 V
Linear range s _i	0...20 mm	0...50 mm

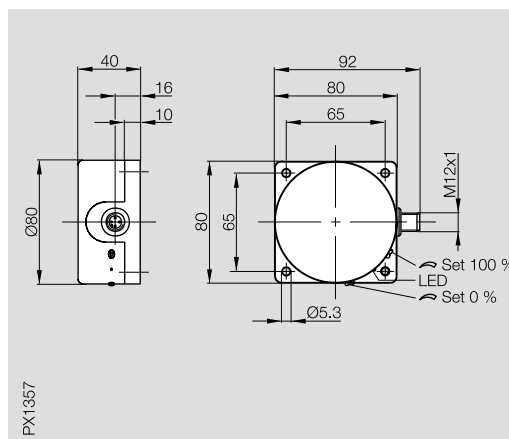
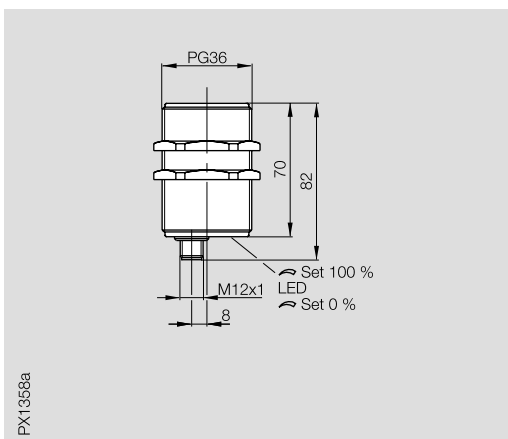

Ordering code	BAW MKZ-471.19-S4	BAW MKK-050.19-S4
Rated operational voltage U _e	24 V DC	24 V DC
Supply voltage U _B	U _e ±20 %	U _e ±20 %
Ripple	≤ 15 % of U _e	≤ 15 % of U _e
Rated insulation voltage U _i	75 V DC	75 V DC
Rated sensing distance s _e	10 mm	25 mm
Load resistance R _L	≥ 10 kΩ	≥ 10 kΩ
No-load supply current I ₀ at U _e	≤ 12 mA	≤ 12 mA
Protected against polarity reversal	yes	yes
Short circuit protected	yes	yes
Ambient temperature range T _a	-10...+70 °C	-10...+70 °C
Temperature drift at s _i	≤ 5 % of U _a max.	≤ 7 % of U _a max.
Max. non-linearity at s _i	≤ 1 % of U _a max.	≤ 2 % of U _a max.
Adjustment indication (end of linear range)	no	no
Degree of protection per IEC 60529	IP 67	IP 67
Housing material	CuZn nickel plated	PBT
Material of sensing face	PBT	PBT
Connection	connector	connector
Recommended connector	BKS-B 19/BKS-B 20	BKS-B 19/BKS-B 20

Wiring diagram



Standard version of BAW MKZ/MKK with rising output curve! These sensors are also available with falling output curve. Please indicate separately when ordering.



The analog set point controller ...

... is powered with 24 V (6; 10). It provides the supply voltage for Balluff analog sensors (1; 5) and is switched directly by their current outputs. Based on these signals, three switchpoints (A1...A3) are output through separate push-pull final stages (PNP/NPN). The switchpoints are individually set using the front-mounted potentiometers. The corresponding switching state is displayed using LED's. The effective direction (rising/falling) can be configured using wire jumpers inside the controller.

Terminal (4) has a voltage output proportional to the current, which can be used for other external analog switching devices (to provide additional switchpoints, for example).

The signal inputs are protected against polarity reversal and the push-pull stages against short circuit (fuse protected internally).

Analog Set Point Controller for analog current and voltage signals

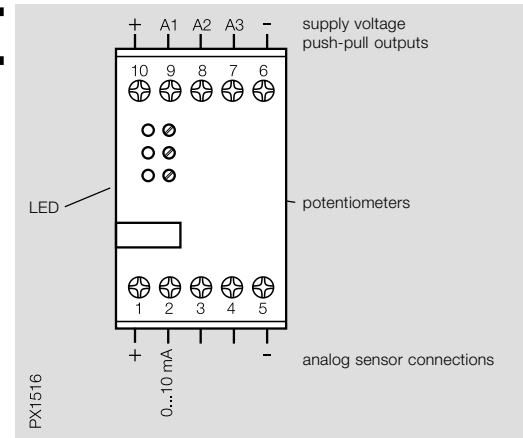

Ordering code	BES 516-611-A-1
Supply voltage U_B	24 V DC
Ripple	$\leq 10\%$
Input circuit	
Current input terminal 2/terminal 3	0...10 mA/0...20 mA
Input resistance	308 Ω /154 Ω
Voltage input terminal 4	0...10 V
Input resistance	13 k Ω
Range of adjustment	3...100 %
Hysteresis (with respect to the pre-set value)	3 %
Output circuit	
Voltage drop PNP transistor	≤ 3.5 V
Voltage drop NPN transistor	≤ 2.5 V
Operational current per push-pull stage	≤ 200 mA
Housing material	PC (fiberglass reinforced)
Housing dimensions b x l x h	74 x 45 x 120 mm
Connection	screw terminals
Max. cross section for connection	up to 2.5 mm ²
Mounting	snap-on rail mount
Ambient temperature range T_a	0...+50 °C
Degree of protection per IEC 60529	terminals IP 20, housing IP 40

Parallel arrangement of set point controllers

Expansion for additional switchpoints

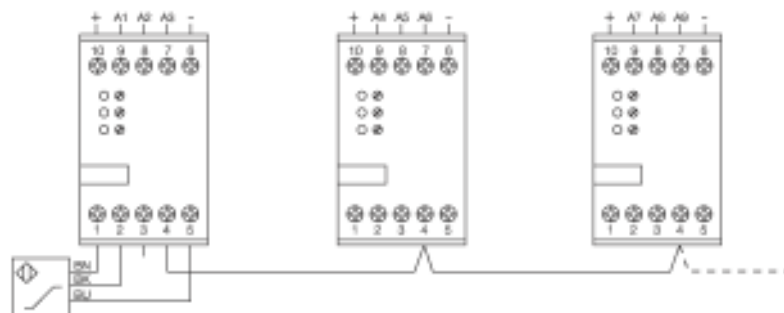

1.7

6

Connectors, clamps ...
page 6.2 ...

Analog sensor with integrated switching outputs

Inductive analog sensors output a signal which is proportional to the target distance. Many applications also call for a switching signal at certain points along the travel distance. These discrete signals are used to indicate when a particular position of the target, generally the moving member of a machine, has been reached. In the past this required the use of an additional, external analog switching device. This separate component has now been eliminated. Balluff has developed an analog sensor with three integrated switching thresholds. These thresholds are programmable and are available as a switching signal on their own dedicated lines. All this is packaged in a standard M18 housing 76 mm in length.

The 3 switching outputs are programmed using a teach-in procedure, whereby the sensor is positioned at the desired switching distance from the object. By connecting the control line with + the switch is "taught", i. e. now knows to switch an output whenever this internal signal level is reached. An LED for each output indicates the switching state of that output. In addition an analog signal from 0 to 10 V is output. The linearity of this signal is $< \pm 3 \%$, with a sensing range of 1...5 mm. The sensor may be flush mounted in steel.

Two in one – sensor and analog set point controller

Instead of mounting two devices, only the sensor itself is necessary. Since programming is remote, the switching outputs can be set even if the sensor is mounted in an inaccessible location.

Approach curve

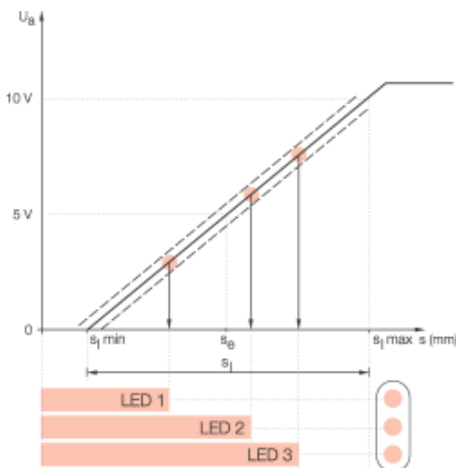

With sensors having the teach-in function the switching distance can be freely programmed within the working range. This can be done either using the BES 516-4 programmer (starting page 6.2 ...) or directly on the control line of the sensor.

Housing size	M18x1
Mounting	flush
Output signal	voltage 0...10 V
Linear range s_1	1...5 mm

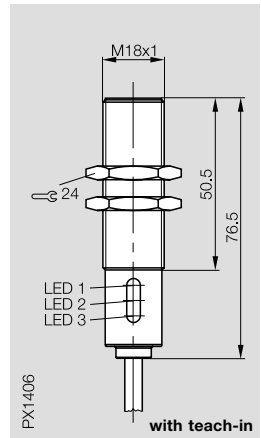

Ordering code	BAW M18M12-UAC50B-...-002
Rated operational voltage U_e	24 V DC
Supply voltage U_B	15...30 V DC
Ripple	$\leq 15 \%$ of U_e
Rated insulation voltage U_i	250 V AC
Rated sensing distance s_e	3 mm
Load resistance R_L for analog output	$\geq 2 \text{ k}\Omega$
No-load supply current I_0 at U_e	$\leq 20 \text{ mA}$
Protected against polarity reversal	yes
Short circuit protected	yes
Ambient temperature range T_a	$-10...+70 \text{ }^\circ\text{C}$
Temperature drift at s_1	$\leq 5 \%$ of $U_a \text{ max.}$
Max. non-linearity at s_1	$\pm 3 \%$ of $U_a \text{ max.}$
Degree of protection per IEC 60529	IP 67
Insulation class	□
Housing material	CuZn nickel plated
Material of sensing face	PBT
Connection	cable
No. of wires x conductor cross section	7 x 0.25 mm ²
Approval	cULus
LED indication for each output	yes
Teach-in function	yes
Hysteresis	$\leq 0.3 \text{ mm}$
Repeat accuracy R	$\leq 0.1 \text{ mm}$
Rated operational current I_e for one switching output	20 mA
Voltage drop U_e at I_e	$\leq 1.5 \text{ V}$

Please add the cable length to the ordering code for sensors with **cable!**
BP03, BP05 = PUR, length 3 m or 5 m

Wiring diagram

