

Uncompromising Quality: More Reliability for Single-Phase and Three-Phase Supply Networks



This is where quality counts twice as much. No wonder, since low-voltage miniature transformers are indispensable components for both the safety of persons and the availability of machines and installations. As safety is so important, quality must not be compromised. Moeller's integrated quality management system to DIN ISO 9001 ensures optimum quality for all products. Each transformer is tested and inspected before it is shipped to the customer. It goes without saying that Moeller's transformers meet the requirements of all international standards and regulations. Furthermore, customers benefit from the prompt delivery of Moeller products and from its closely-knit global service network.

Universal power supplies AING for the clever control voltage supply



Safety transformer

1. fuse elements for every secondary voltage
2. three output voltages (24 V AC, 10 V DC, 24 V DC)
3. all connections on one side
4. illuminated displays and signalling contacts for every voltage

Several typical voltages are now established as control voltages in the control panel. The most commonly used are 24 V AC as well as 10 V and 24 V DC. Up to now several power supply units which had to be separately mounted and wired were required. The power supply units AING provide all three output voltages from a single device. Each voltage has its own LED, a changeover contact for signalling purposes, an integrated fuse and is pre-wired. This assures significant savings in time and space as well as additional safety. Thus, the economic efficiency of you installation is significantly enhanced.

The power supplies are open, non-stabilized transformer power supplies with galvanically isolated windings conform to EN 61558-2-6, with the connection area in fingerproof design to VBG 4. They feature three isolated outputs to supply power to electrically systems, e.g. in the HVAC field. All outputs are protected against short-circuit with conventionally available and attractively priced automobile fuses (Size/type FK2). A potential free relay contact (changeover contact) is featured for monitoring and signalling of the individual output voltages. In addition,

Everything from a single source: transformer protection with PKZM0-...-T

Moeller can supply exactly the ideal motor-protective circuit-breaker for protecting its transformers. Thanks to its high-speed short-circuit release it can withstand virtually any inrush current. For example, a suitable protective device and the primary current required by the relevant standards are specified on the isolating and safety transformers. This makes it easy to find the correct motor-protective circuit-breaker PKZ from our selection lists. Yet another way of serving our customers.



an LED indicates the "Power on" state of each output (LED green) and "Fuse defective" (LED red).

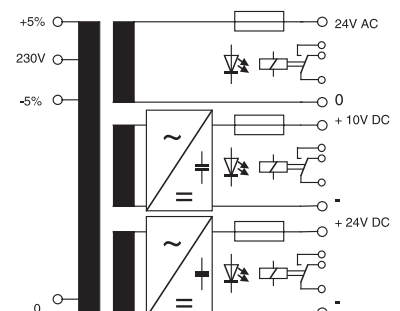

Controlling, Isolating, Protecting: Flexible Solutions for Worldwide Use



Control transformers: for the right voltage

Moeller control transformers ensure reliable operational voltage for control and auxiliary circuits in power distribution and automation applications, offering total reliability all the time. Control transformers allow machines and plants to be adapted to the different supply voltages and voltage types found all over the world. Standard additional tapings of +/- 5% of the primary voltage increase the operational safety of electrical control systems when the mains supply is subject to continuous overvoltages and undervoltages. Control transformers reduce the short-circuit current in the event of a fault and enable the unearthed operation of auxiliary current circuits.



Isolating transformers: reinforced insulation

The isolating transformers are provided with reinforced insulation between the primary and secondary windings. In this way, these transformers meet the most rigorous safety requirements, and are suitable for the "safe" isolation of current circuits in hazardous areas with an electrically conductive environment.

Safety transformers: increased all over protection

Safety transformers offer a high degree of protection for use in rugged applications such as wet grinding machines, concrete vibrators etc. The safety transformers are a type of isolating transformer with a maximum secondary voltage of ≤ 50 V.



3 in 1 – three in one

STI, STZ, DTI, DTZ and UTI control, isolating and safety transformers offer maximum safety for your machines and installations. Worldwide use is guaranteed by the wide range of approvals available and compliance with international standards.



Terms and definitions with transformers

Rated values

Rated values are rated voltage, nominal current (r.m.s. values), VA rating, rated frequency and rated transformation ratio, which the transformers feature and for which they are rated.

Rated input voltage

The rated input voltage is the supply voltage of a transformer for defined operating conditions.

Rated output voltage

The rated output voltage is the voltage on the output of a transformer at the rated input voltage, rated output current and rated power factor.

No-load voltage

No-load voltage is the output voltage of an unloaded transformer at rated frequency.

No-load current

No-load current is the current on the input of an unloaded transformer at rated input voltage and rated frequency.

VA rating

VA rating is the power on the output side of the transformer. It is the product of rated output voltage and rated output current. If the secondary side of the transformer features additional tapings, the VA rating is the sum of



Even more functionality through accessories: the matching transformers

A large number of accessories are available to enhance the functionality of Moeller matching transformers. Transformers mounted in special steel enclosures offer additional touch protection. IP 65 enclosures are available for applications requiring additional protection. The standard winding isolation can also be provided with additional screening (screen winding) between the primary and secondary circuit. A special isolating coating ensures that transformers are suitable for ambient conditions with a high relative humidity. Inrush current limiters attached directly to the primary terminal reduce inrush current and make it easier to protect transformers against short-circuits.

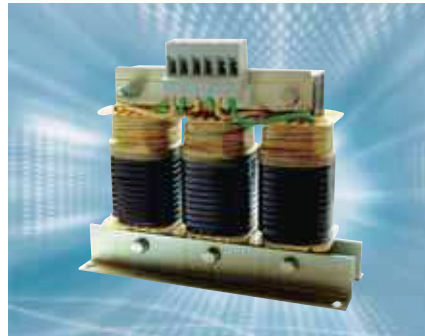

Motor reactors are used on the output of the frequency inverters

Motor reactors reduce the slew rate of the output voltage ($du/dt < 500V/\mu s$), as well as motor noise and heating. The use of motor reactors enables the permissible motor cable lengths to be extended up to a max. of 200 m. Connection of a reactor to the output of the frequency inverter is recommended with parallel operation of several motors.



Economic operation with starting transformers

Starting transformers DTA are a special type of economy transformer. Starting transformers are used as current limiters for starting three-phase induction motors, thus eliminating supply voltage dips, for example, with weak networks and larger motors. Of course, Moeller can also produce customized transformers if the type of transformer a customer needs is not available in our catalogue. Regardless of whether a transformer is needed for lighting a runway or for a wind-power station, or whether a miniature transformer or a transformer for high output is required, Moeller applies its extensive technical expertise to achieve top-quality results.

the products of the rated output voltage and the rated output current of all simultaneously loaded circuits.

Short-time rating

The short-time rating is the rating on the output of a control transformer at a $\cos \phi = 0.5$ and voltage drop of maximum 5% compared to the rated output voltage.

Short-circuit voltage

The short-circuit voltage is the voltage which is applied to the input windings, so that rated output current flows (windings at room temperature) when the output windings are short-circuited. It is stated in % of the rated input voltage.

No-load loss = iron losses

Consumed active power, if the rated input voltage at rated frequency is

applied to the input winding and the output winding is unloaded.

Short-circuit losses = copper losses

Consumed active power, if the output side is short-circuited and nominal output current is flowing.