

# Process Protection

7









7/2	<b>Product overview</b>
7/3	<b>Acoustic and motion sensing</b>
7/5	<b>Acoustic sensor for pump monitoring</b> SITRANS DA400
7/10 7/14	<b>Acoustic sensors for material flow monitoring</b> SITRANS AS100 SITRANS CU02
7/17 7/23 7/25	<b>Motion sensors</b> Milltronics MFA 4p Milltronics Millpulse 600 SITRANS WM100

You can download all instructions, catalogs and certificates for Process Protection free of charge at:  
[www.siemens.com/processprotection](http://www.siemens.com/processprotection)

# Process Protection

## Product overview

### Overview

	Application	Device description	Page
<b>Acoustic sensor for pump monitoring</b>			
	Acoustic diagnostics unit for flow valve leakage monitoring in oscillating displacement pumps or for material flow monitoring of bulk solids in pipes, conveyors or raceways	<b>SITRANS DA400</b> <ul style="list-style-type: none"> <li>• 4 inputs for structure-borne noise sensors</li> <li>• 4 universal inputs</li> <li>• 6 digital outputs</li> <li>• With PROFIBUS DP or PROFIBUS PA</li> <li>• Sensor degree of protection IP66/IP68</li> </ul>	7/5
<b>Acoustic sensors for material flow monitoring</b>			
	Acoustic sensor for solids flow detection	<b>SITRANS AS100</b> <ul style="list-style-type: none"> <li>• Non-invasive</li> <li>• Screw in, bolt on, weld, or bond in place</li> <li>• Analog output</li> <li>• High and low sensitivity range of operation</li> </ul>	7/10
	Alarm control unit for use with SITRANS AS100 acoustic sensor to provide reliable continuous protection for bulk solid flow  It processes signals from the sensor, providing relay and analog outputs for interface into a process	<b>SITRANS CU02</b> <ul style="list-style-type: none"> <li>• 3 digit LCD display</li> <li>• 4 to 20 mA output</li> <li>• Two programmable relays</li> <li>• Adjustable independent time delay for each relay</li> <li>• DIN rail mounting provides easy installation</li> </ul>	7/14
<b>Motion sensors</b>			
	Highly sensitive single set point motion sensor alarm unit, used with MSP and XPP probes	<b>Milltronics MFA 4p</b> <ul style="list-style-type: none"> <li>• Probe/target separation up to 100 mm (4")</li> <li>• Minimum velocity of moving ferrous target: 1 cm/sec. (2 fpm)</li> </ul>	7/17
	Heavy-duty 2-wire motion sensor providing solid state switch output to PLCs between 18 to 135 V AC or DC	<b>Milltronics Millpulse 600</b> <ul style="list-style-type: none"> <li>• Provide pulse output to PLC input when monitoring speed of rotating, reciprocating or conveying equipment</li> </ul>	7/23
	Heavy-duty zero speed alarm switch	<b>SITRANS WM100</b> <ul style="list-style-type: none"> <li>• Detects the absence or presence of motion of rotating or reciprocating or conveying equipment</li> </ul>	7/25

### Overview

Process protection devices act as early warning systems to avoid costly process interruptions and breakdowns of equipment. Non-contacting motion sensors detect changes in motion and speed of conveying, reciprocating and rotating machinery.

Non-invasive acoustic sensors detect inaudible, high frequency acoustic emissions generated by friction and impact, caused by materials in motion. They can detect conditions of flow/no flow or high/low flow, to warn of blockages, product absence or equipment failure. They are located outside of the process, accurately detecting conditions without wear on the sensor.

Motion sensors can warn in case of equipment malfunction and shut down machinery in case of a slowdown or failure. They are rugged and perform even in harsh industrial conditions. All of the MFA 4p motion sensing probes as well as the Millpulse 600 can be mounted up to 100 mm (4") from the ferrous target, reducing the chance of damage to the probe and the equipment. The probes are not affected by moisture or dust build-up.

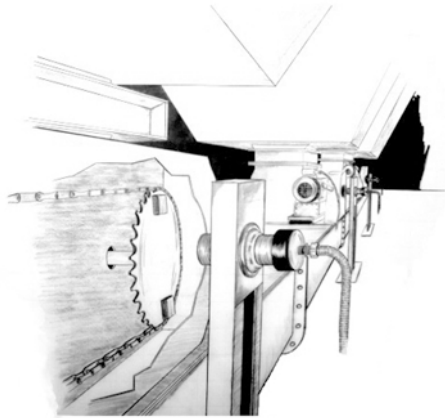

Motion sensing on drive shaft of rotary feeder

### Mode of operation

#### Acoustic Sensing

Acoustic sensors monitor high frequency emissions generated by friction and the impact of flowing material or mechanical parts. The sensors can also sense the turbulence of gases or liquids leaking through valves and flanges. When matter vibrates between 0 Hz and 200 kHz, it creates acoustic energy. Sound energy between 20 Hz and 20 kHz can be detected by humans. Acoustic sensors detect high-frequency acoustic energy between 75 kHz and 175 kHz. Acoustic energy travels quickly through dense materials (metal) and poorly through less dense materials (air). Because the acoustic sensors are mounted directly to the external wall of the chute work, other plant noises are well below 75 kHz and effectively ignored by the sensors.

The acoustic sensors contain a specialized piezocrystal and filter circuit that responds effectively to the high-frequency band between 75 kHz and 175 kHz. As the crystal is excited by the acoustic energy, it produces a continuous electrical signal in direct proportion to the level of acoustic energy received. The SITRANS AS100 sensor output of 0 to 10 V DC can be applied to a PLC or to an optional control unit for a programmable alarm relay or 4 to 20 mA signal output.

#### Motion sensing

Siemens Milltronics probes work on the principle of Faraday's Laws of Electromagnetic Induction. When a ferromagnetic object enters the probe's permanent magnetic field, it distorts the flux, causing its coil windings to generate a voltage. This voltage is proportional to the strength of the magnet and the number of wire turns in the coil (constant in the probes) and the speed at which the ferrous target passes through the flux. The generated voltage is also inversely proportional to the square of the distance between the target and the probe.

The robust motion sensors provide the contacts to shut down machinery whenever under-speed, over-speed or plant equipment failure occurs. On belt, drag and screw conveyors, or on bucket elevators, fans and pumps, the speed alarm option can warn instantly of equipment malfunction. Some probes may be linked to a programmable logic controller to monitor equipment.

# Process Protection

## Acoustic and Motion Sensing

### Technical specifications

#### Process Protection Selection Guide

Criteria	SITRANS DA400	SITRANS AS100	Milltronics MFA 4p	Milltronics Millpulse 600	SITRANS WM100
Typical industries	Mining, water/wastewater, chemicals/petrochemicals and oil & gas industry	Aggregates, grain, cement, food processing, power generation, steel processing	Aggregates, cement, mining, wastewater, grain	Aggregates, cement, mining	Aggregates, cement, mining
Typical Applications	Oscillating displacement pumps such as diaphragm piston pumps, piston pumps and hose-type diaphragm piston pumps. Monitoring of flowing materials in pipes, conveyors or channels.	Pipes, pneumatic conveyors, aerated gravity flow systems, burst filter bag detection	Tail pulleys, driven pulleys, motor shaft sensing, screw conveyor flights, bucket elevators	Tail pulleys, driven pulleys, motor shaft sensing, screw conveyor flights, bucket elevators	Tail pulleys, driven pulleys, motor shaft sensing, screw conveyor flights, bucket elevators
Operation	Acoustic detection of cavitation, optionally acoustic detection of impact noises of high frequency	Acoustic sensing	Motion sensing	Motion sensing	Motion sensing
Enclosure	Electronics housing, Makrolon IP65, sensor, stainless steel material number W.-Nr. 1.4571 (316Ti SST)	Compact 304 or 303 stainless steel, IP68	Type 4X/NEMA 4X/IP65 polycarbonate	Type 4X/NEMA 4X/IP67 aluminum	Type 4X/NEMA 4X/IP67 aluminum
Sensor mounting	Screw to outside of pump housing. For material flow monitoring on the outside of pipes, channels, chutes or raceways	Sensor non-invasive: glue or weld-on disc, bolt or weld-on tab, drill and tap	Non-contacting probes secured with supplied flange	Non-contacting, secured with supplied flange	Non-contacting, secured with supplied flange
Operating temperature	Electronics -20 °C ... +60 °C (-4 °F ... +140 °F) Sensor -20 °C ... +110 °C (-4 °F ... +230 °F)	-20 ... +80 °C (-4 ... +176 °F) <sup>1)</sup>	-20 ... +50 °C (-4 ... +122 °F) <sup>2)</sup>	-40 ... +60 °C (-40 ... +140 °F)	-40 ... +60 °C (-40 ... +140 °F)
Power requirements	19 V ... 36 V DC, < 100 mA	20 ... 30 V DC, 18 mA	100/115/200/230 V AC ± 10 % 50/60Hz, 15 VA	Switch 18 ... 48 V AC/DC or 60 ... 135 V AC/DC	115 or 230 V AC ± 10 % 50/60 Hz, 7 VA
Approvals	CE, PROFIBUS DP and PROFIBUS PA conform, Ex protection to ATEX 1G or 1D	CE, C-TICK, CSA/FM Class II, Div. 1, Group E, F, G optional, ATEX II 3D optional	CSA <sub>US/C</sub> , CE, C-TICK	CSA <sub>US/C</sub> , CE, C-TICK	CSA <sub>US/C</sub> , CE, C-TICK

<sup>1)</sup> Extended temperature model -40 to +125 °C (-40 to +257 °F) available (CE version)

<sup>2)</sup> Probes available for -40 to +260 °C (-40 to +500 °F)

# Process Protection

## Acoustic sensors for pump monitoring

SITRANS DA400

### Overview



SITRANS DA400 acoustic diagnostic unit and sensor

The SITRANS DA400 acoustic diagnostic unit acoustically measures the structure-borne noise

- in the version for pump monitoring; on oscillating displacement pumps
- in the version for material flow monitoring; on pipes, conveying equipment or channels.

It comprises an electric diagnostic unit and up to four acoustic sensors.

### Benefits

#### Benefits when pump monitoring

- Increased availability of the system through:
  - Advanced maintenance planning thanks to early recognition of defective components
  - Reduced downtimes (no fault locating necessary)
  - Increased maintenance intervals
  - Greater pump reliability
- Prevention of expensive consequential damage
- Increased safety of critical applications
- Early recognition of a reduction in power
- Increased productivity

#### Benefits when material flow monitoring

- Detection of insufficient or excessive inflow of material in a liquid or gas flow
- Detection of blockages or clogging
- Reduction of down times
- Increased product quality
- Increased availability
- Guaranteed operational safety
- Increased productivity

### Application

In the version for pump monitoring, the SITRANS DA400 allows continuous, simultaneous and independent monitoring of up to four flow control valves in a pump for leaks. In addition, another four inputs are available for monitoring standard signals (e.g. diaphragm and temperature monitoring). This means that the con-

dition of an oscillating displacement pump is monitored in every phase of its operation.

The SITRANS DA400 is used in all industries where an oscillating displacement pump is used.

The version for material flow monitoring monitors the material flow in liquids or gases that is usually as a result of impact or friction, e.g. against the pipe or channel wall.

If the acoustic diagnostic unit is used in potentially explosive areas, the sensors as well as the acoustic diagnostic unit can be installed in the Ex-zone.

If using the unit in potentially explosive areas, you have two options:

- Operation of the sensors over the safety barriers or
- Operation of the sensors over the SITRANS DA400 with explosion protection.

### Function

#### Product features

Continuous and independent status monitoring:

- of the flow control valves, for leaks
- of the membranes, for material fatigue
- of the temperature loading of the hydraulic oil
- of flowing bulk solids in pipes, conveying equipment or channels

Communication of the status to superordinate control systems:

- via digital outputs
- digitally, via PROFIBUS DP or PROFIBUS PA

Simple to operate and parametrize:

- locally, via digital display and keys
- PROFIBUS DP and PROFIBUS PA

#### Mode of operation

##### Principle of measurement

Leaks in the flow control valves of oscillating displacement pumps are flows in which cavitation occurs. This results in sound waves that are transmitted to the valve housing, where they are recorded by the structure-borne sound sensor in the SITRANS DA400 on the outside.

The SITRANS DA400 utilizes the fact that with both an open valve and a closed intact valve, no cavitation occurs and the measured sound level thus corresponds to the operating noise of the pump. By contrast, with a closed defective valve cavitation does occur, which can be identified by a period increase in the sound level (see figures). The measured value from the SITRANS DA400 corresponds exactly to this increase in the sound level.

In the version for material flow monitoring, SITRANS DA400 continuously detects high-frequency acoustic oscillations by means of structure-born noise sensors.

These oscillations are created by:

- Friction and impact of bulk solids in:
  - pipes, raceways or channels
  - chutes
  - conveyors
- Friction and impact of mechanical parts
- Bursting of bubbles
- Cavitation
- Turbulence in gas and liquid flows

# Process Protection

## Acoustic sensors for pump monitoring

### SITRANS DA400

The following shows an example of signal levels at an oscillating displacement pump.

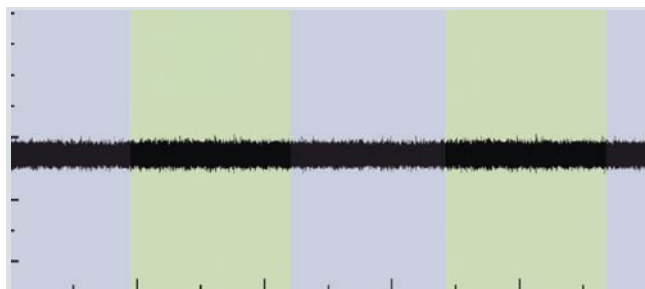

Signal from structure-borne sound sensor with intact valve



Signal from structure-borne sound sensor with defective valve

#### Sensor operation

The structure-borne sound sensor works on the piezoelectric principle. The structure-borne sound is injected into the sensor via the sensor base (mounting surface) and inside it is converted into an electrical voltage by a piezo-ceramic element. This is amplified in the sensor and transmitted via the cable.

The sensor frequency range lies in the ultrasonic range (> 20 kHz). The sensor is non-directional, i.e. the angle at which the sound wave impacts on the sensor base is not important.

#### Mode of operation of the safety barrier

The safety barrier comprises intrinsically-safe circuits. These circuits serve to operate intrinsically-safe components such as sensors and to isolate safety from the non-hazardous area with the SITRANS DA400 diagnostic unit.

#### Technical specifications

SITRANS DA400	Without Ex protection	With Ex protection
<b>Input</b>		
Acoustic channels		4
• Cycle time		10 ms
Only for connection to intrinsically safe sensors with:		
• Max. voltage $U_o$	-	≤ 5.5 V
• Max. current $I_o$	-	≤ 70 mA
• Max. power $P_o$	-	≤ 100 mW
• Internal capacitance $C_i$	-	≤ 1.2 μF
• Internal inductance $L_i$	-	Negligible
Universal inputs		4
• Cycle time		80 ms
• Low pass filter time		1 s

SITRANS DA400	Without Ex protection	With Ex protection
Universal analog current input		
• Load	< 105 Ω	< 12 Ω
• Resolution		0.1 %
• Accuracy		0.5 %
• Fault signal	> 21 mA or < 3.6 mA (at 4 ... 20 mA)	
• Alarm monitoring hysteresis	0.5 %	
• Static destruction limit	40 mA, 4 V	-
For connection with approved intrinsically safe circuits with:		
• Max. supply voltage $U_i$	-	≤ 30 V
• Max. short-circuit current $I_i$	-	≤ 100 mA
• Max. power $P_{oi}$	-	≤ 1 W
• Internal capacitance $C_i$	-	≤ 11 nF
• Internal inductance $L_i$	-	≤ 70 μH
Universal input 24 V digital signal		
• Input resistance		> 19 kΩ
• Signal level Low		< 4.5 V or open
• Signal level High		> 7 V
• Hysteresis		> 1 V
• Static destruction limit	± 40 V	-
For connection with approved intrinsically safe circuits with:		
• Max. supply voltage $U_i$	-	≤ 30 V
• Max. short-circuit current $I_i$	-	≤ 100 mA
• Max. power $P_{oi}$	-	≤ 1 W
• Internal capacitance $C_i$	-	≤ 11 nF
• Internal inductance $L_i$	-	≤ 70 μH
Universal input closing contact		
For connection to closing contact with the maximum values:		
• Max. voltage $U_o$	-	≤ 10 V
• Max. current $I_o$	-	≤ 1 mA
• Max. power $P_o$	-	≤ 5 mW
• Internal capacitance $C_i$	-	≤ 11 nF
• Internal inductance $L_i$	-	≤ 70 μH
8.2 V source for NAMUR signal (DIN EN 60947-5-6)		
• Open circuit voltage	8.2 V ± 0.3 V, short-circuit proof	-
• Input resistance	< 950 Ω	-
• Static destruction limit for incorrect wiring	+20 V/-10 V	-
<b>Output</b>		
Digital outputs	6	6 (applicable for NAMUR switch hardener)
• Semiconductor relay	Individually isolated, short circuit-proof	-
• Switching voltage	24 V AC/36 V DC, any polarity	-
• Destruction limit	35 V AC, 50 V DC	-
• Max. switching current	100 mA	-
• Signal status Low (no response)	-	≤ 1.2 mA (source to DIN 19234)
• Signal status High (response)	-	≥ 2.1 mA (source to DIN 19234)

# Process Protection

## Acoustic sensors for pump monitoring

SITRANS DA400

SITRANS DA400	Without Ex protection	With Ex protection
For connection with an intrinsically safe switching amplifier to DIN 19234 with:		
• Max. supply voltage $U_i$	-	≤ 15.5 V
• Max. short-circuit current $I_i$	-	≤ 25 mA
• Max. power $P_{oi}$	-	≤ 64 mW
• Internal capacitance $C_i$	-	≤ 5.2 nF
• Internal inductance $L_i$	-	Negligible
<b>Conditions of use</b>		
Installation conditions	Vertical wall mounting, cables fed in from below	
Climatic class	Class 4K4 according to EN 60721-3-4	
Mounting location	-	Zone 1 or zone 2
Permissible ambient temperature	-20 ... +60 °C (-4 ... +140 °F)	-
• Temperature class T5 – T1	-	-20 ... +60 °C (-4 ... +140 °F)
• Temperature class T6	-	-20 ... +50 °C (-4 ... +122 °F)
Mechanical load	Class 4M3 according to EN 60721-3-4	
Degree of protection to EN 60529	IP65	
Electromagnetic Compatibility	To EN 61326 and NAMUR NE 21	
Usage limits for water		
• Delivery side	≥ 10 bar a	
• Number of strokes	min. 4 min <sup>-1</sup> , max. 10 ... 500 min <sup>-1</sup>	
<b>Design</b>		
Weight (without options)	approx. 2.5 kg	
Dimensions (W x H x D) in mm (inch)	172 x 320 x 80 (6.8 x 12.6 x 3.2)	
Enclosure material	Macrolon (polycarbonate + 20 % glass fiber)	Makrolon (Polycarbonate + 20 % glass fibers), surface attenuated with CrNi layer and painted
Electrical connection via screw terminals	<ul style="list-style-type: none"> <li>• Rigid 2.5 mm (0.984 inch)</li> <li>• Flexible 1.5 mm (0.59 inch)</li> <li>• Flexible with connector sleeves 1.5 mm (0.59 inch)</li> </ul>	
Cable inlet via plastic cable joints	<ul style="list-style-type: none"> <li>• 2 x Pg 13.5</li> <li>• 5 x Pg 11</li> </ul>	
<b>Power supply</b>		
Rated voltage	24 V DC	16 V DC
Operating range	19 ... 36 V DC	15 ... 17 V DC
Current consumption	< 100 mA	< 40 mA
For connection with approved intrinsically safe circuits with:		
• Max. supply voltage $U_i$	-	≤ 17.4 V
• Max. short-circuit current $I_i$	-	≤ 191 mA
• Max. power $P_{oi}$	-	≤ 1.35 W
• Internal capacitance $C_i$	-	≤ 33 nF
• Internal inductance $L_i$	-	≤ 28 μH

SITRANS DA400	Without Ex protection	With Ex protection
<b>Certificates and approvals</b>		
Explosion protection to EN 50014, EN 50020 and EN 50021		
• Intrinsic safety "i"	-	TÜV (German Technical Inspectorate) 06 ATEX 2952
• Marking	-	II 2(1) G EEx is [ia] IIC T6
<b>Communication</b>		
PROFIBUS DP	RS485, switchable terminating resistor	
Protocol	Cyclic with Master C1 and acyclic with Master C2	
Power supply	-	Bus-supplied
Bus voltage	-	9 ... 24 V
Current consumption	-	10.5 mA ± 10 %
Bus connection with FISCO supply unit, ia/ib group IIC or IIB	-	Yes
Layer 1 and 2 from PROFIBUS PA, transfer technology from IEC 1158-2		
• C2 connections	-	4 connections are supported in master class 2
• Device profile	-	PROFIBUS PA Profil V3.0 Rev. 1, Class B
• Device address	-	1 ... 126 (126 factory-set)
PC parameterization software	SIMATIC PDM (not included in the scope of delivery)	
<b>Sensor for SITRANS DA400</b>		
<b>Setup</b>		<ul style="list-style-type: none"> <li>• Piezoceramic sensor with pre-amplifier</li> <li>• Encapsulated electronics</li> <li>• 4-wire cable with anti-kink sleeve</li> </ul>
<b>Conditions of use</b>		
Permissible Ambient Temperature	-40 ... +110 °C (-40 ... +230 °F)	
Degree of protection to EN 60529	IP66/IP68	
Mechanical load	Class 4M7 according to EN 60721-3-4	
Climatic class	Class 4K4 according to EN 60721-3-4	
<b>Design</b>		
Housing material	Stainless steel 1.4571 (316Ti SST)	
Cable	Ends with wire protectors and cable shoe for connection to the SITRANS DA400	
Weight	125 g (0.276 lb)	
Mounting location	Zone 0/1 or zone 20/21/22	
Dimensions (W x H x D) in mm (inch)	26 x 29 x 40 (1.02 x 1.14 x 1.57)	

7

# Process Protection

## Acoustic sensors for pump monitoring

### SITRANS DA400

#### Sensor for SITRANS DA400

<b>Power supply</b>	Power fed from device
<b>Certificates and approvals</b>	
Explosion protection	
Intrinsic safety "i"	TÜV 2005 ATEX 2876 X
Marking	II 1 G EEx ia IIC T6/T5/T4 or II 1 D EEx ia D 20/21/22 T160
Permissible ambient temperature	
• Category 1G	
- Temperature class T4, T5	-20 ... +60 °C (-4 ... +140 °F)
- Temperature class T6	-20 ... +50 °C (-4 ... +122 °F)
• Category 2G	
- Temperature class T4	-40 ... +110 °C (-40 ... +230 °F)
- Temperature class T5	-40 ... +80 °C (-40 ... +176 °F)
- Temperature class T6	-20 ... +65 °C (-4 ... +149 °F)
• Category 1D or 2D	
- Temperature class T160	-40 ... +110 °C (-40 ... +230 °F)

#### Ex barriers for sensors

<b>Application area</b>	For the intrinsically safe supply of the acoustic sensors in zone 1; the safety barriers must be installed between the SITRANS DA400 acoustic diagnostic unit and the sensor if only the sensors are being operated in the Ex zone.
-------------------------	-------------------------------------------------------------------------------------------------------------------------------------------------------------------------------------------------------------------------------------

<b>Input</b>	A maximum of two sensors can be connected.
--------------	--------------------------------------------

#### Conditions of use

Degree of protection to EN 60529	IP20
Permissible Ambient Temperature	-20 ... +60 °C (-4 ... +140 °F)

#### Design

Weight	115 g (0.254 lb)
Housing material	Plastic, polyamide
Type of installation	Installation on mounting rail NS 32 or NS 35/7.5. The acoustic diagnostic unit SITRANS DA400 and the safety barrier must be operated outside the Ex zone.

Dimensions (W x H x D) in mm (inch)	68 x 77 x 42 (2.68 x 3.03 x 1.65)
-------------------------------------	-----------------------------------

#### Certificates and Approvals

Explosion protection	
• Intrinsic safety "i"	TÜV 05 ATEX 2917 X
• Marking	II (2) G [EEx ib] IIC

#### Selection and Ordering data

<b>Acoustic diagnostics unit SITRANS DA400</b> with local programming and display	Order-No. <b>7MJ2400 - A 0</b>
--------------------------------------------------------------------------------------	--------------------------------

#### Communication

• PROFIBUS DP	1 A
• PROFIBUS PA	2 B

#### Explosion protection

• without	A
• with EEx ia/ib to ATEX <sup>1)</sup>	B

#### Application software

for continuous condition monitoring of positive displacement pumps	1
for material flow monitoring in pipes, raceways and conveyors	2

#### Acoustic sensors for diagnostics unit SITRANS DA400

Order-No. **7MJ2000 - 1 0 0**

#### Explosion protection

• without	A
• with EEx ia to ATEX	B

#### Cable

(incl. pin and allen screw M6)	
20 m	B
40 m	C
100 m	F

#### Safety barriers for sensors

D) **7MJ2010-1AA**

for rail mounting NS 32 and NS35/7.5 in non hazardous areas  
Explosion-protected output circuit EEx ib

<sup>1)</sup> Not in combination with trigger sensor.

D) Subject to export regulations AL: N, ECCN: EAR99H.

#### Dimensional drawings

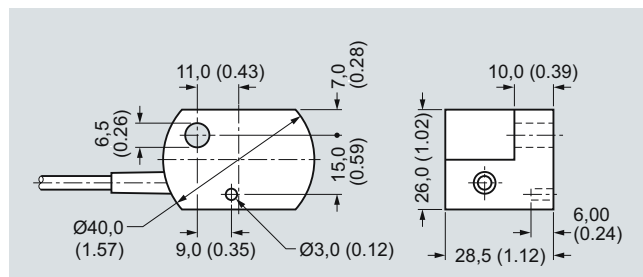

Sensor for SITRANS DA400, dimensions in mm (inch)

# Process Protection

## Acoustic sensors for pump monitoring

SITRANS DA400

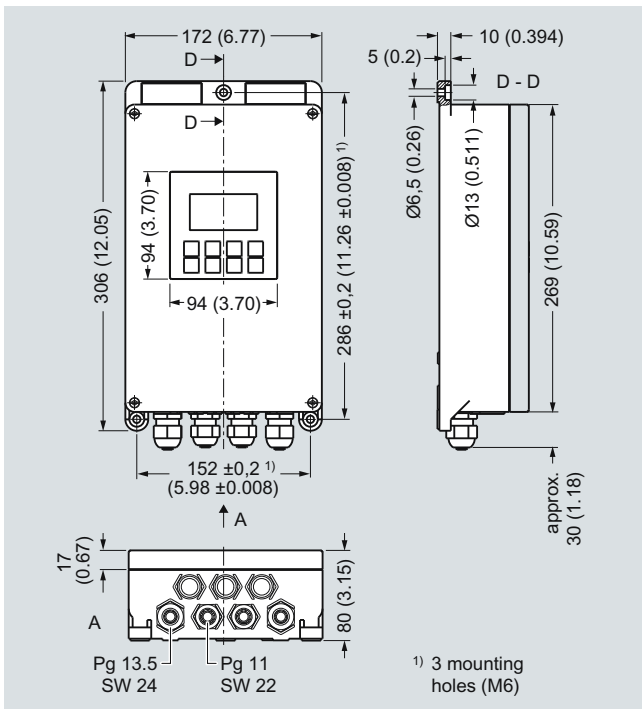

SITRANS DA400, dimensions in mm (inch)

### Schematics

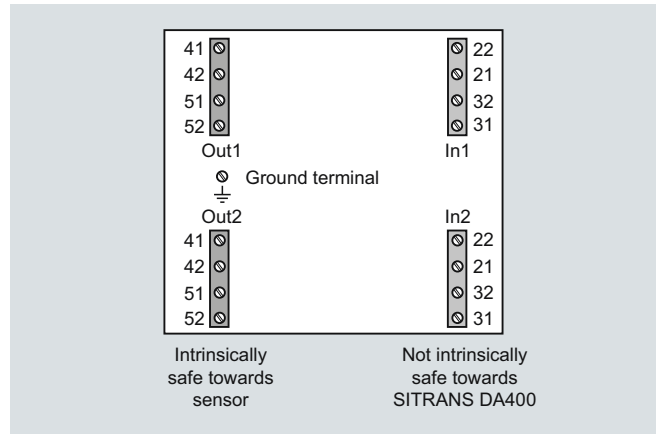

Safety barrier for SITRANS DA400, terminal assignment

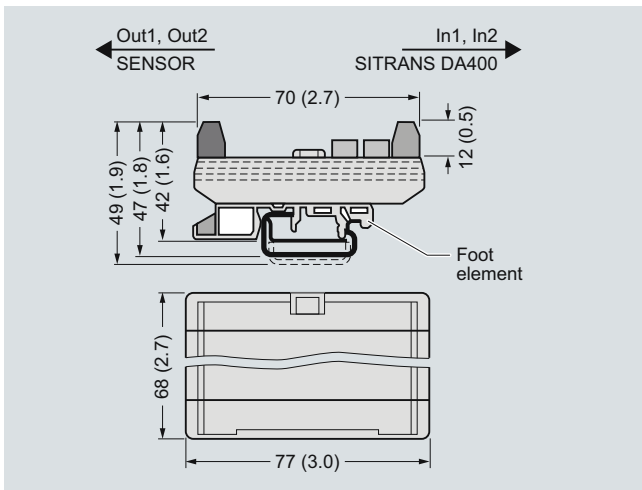

Safety barrier for SITRANS DA400, dimensions in mm (inch)

	DO 1	DO 2	DO 3	Sens 3	Sens 4	In 3	In 4	PROFIBUS
L+/-	31 32	41 42	51 52	yl gr br bl	yl gr br bl	I+ ⊥ DI 8V	I+ ⊥ DI 8V	A B
Supply	81 82	71 72	61 62	15 16 17 18	25 26 27 28	55 56 57 58	65 66 67 68	91 92
24V DC	DO 6	DO 5	DO 4	Sens 1	Sens 2	In 1	In 2	PROFIBUS

- L+/- Power supply (Any polarity with PROFIBUS PA)
- DO Digital output
- Sens Sensor
- In Input
- yl yellow
- gr green
- br brown
- bl black
- I+ Analog current input +
- ⊥ Ground
- DI Digital input
- A Signal A (green) with PROFIBUS DP, any with PROFIBUS PA
- B Signal B (red) with PROFIBUS DP, any with PROFIBUS PA

SITRANS DA400, terminal assignment

# Process Protection

## Acoustic sensors for material flow monitoring

### SITRANS AS100

#### Overview



SITRANS AS100 is an acoustic sensor used for solids flow detection.

#### Benefits

- Non-invasive
- Screw in, bolt on, weld, or bond in place
- Analog output
- High and low sensitivity range of operation

#### Design

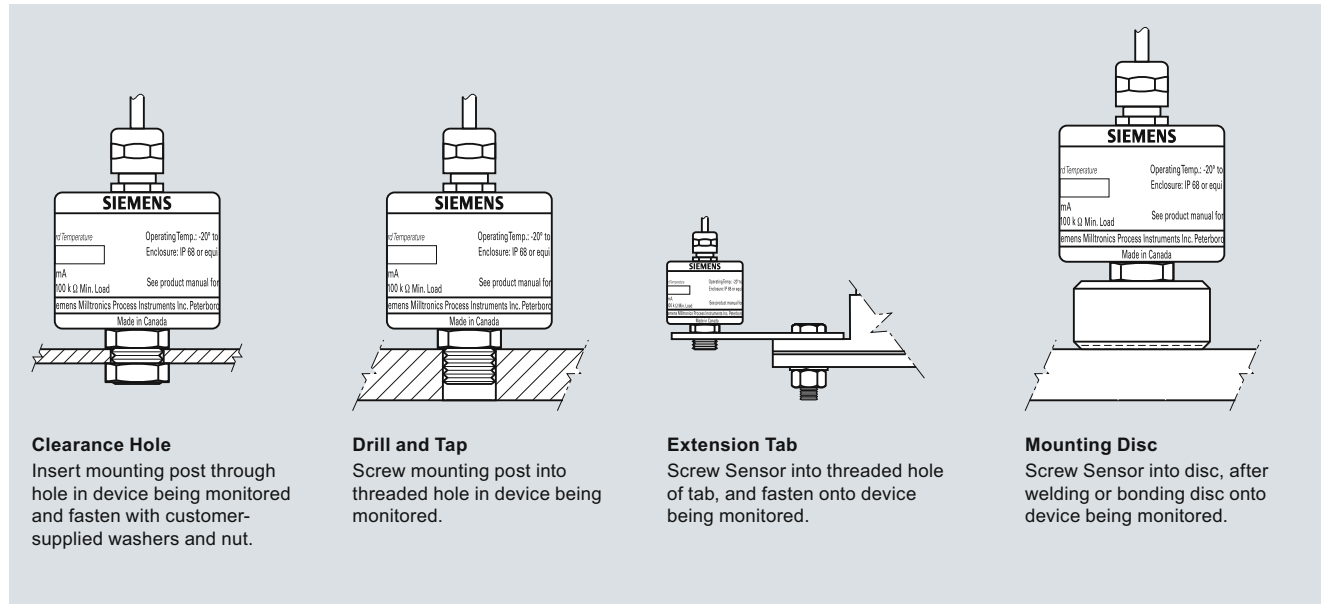

##### Clearance Hole

Insert mounting post through hole in device being monitored and fasten with customer-supplied washers and nut.

##### Drill and Tap

Screw mounting post into threaded hole in device being monitored.

##### Extension Tab

Screw Sensor into threaded hole of tab, and fasten onto device being monitored.

##### Mounting Disc

Screw Sensor into disc, after welding or bonding disc onto device being monitored.

#### Application

SITRANS AS100 detects changes in high frequency sound waves from equipment and materials in motion. It detects and reacts instantly to changes in solids flow to warn of blockages, product absence, or equipment failure such as burst filter bags. This allows an operator to take early preventative action and avoid costly damage.

Common applications include pellets, powders and most bulk solids in pipes, chutes, vibratory feeders, pneumatic conveyors or aerated gravity flow systems.

Operating with a SITRANS CU02 control unit, the system detects conditions of high flow, low flow or no flow. It can be added to a control loop via a 4 to 20 mA output. Two relays are fully programmable and independent of each other and can be used to operate an alarm or control device.

With no moving parts and a type 304 or 303 stainless steel enclosure sealed against dust and moisture, this non-invasive unit requires little or no maintenance. With a dual operating range, the sensor offers an exceptionally wide range of application capabilities.

- Key applications: pipes, chutes, vibratory feeders, aerated gravity flow systems, burst filter bag detection

# Process Protection

## Acoustic sensors for material flow monitoring

SITRANS AS100

Technical specifications		Selection and Ordering data	Order No.
<b>Mode of Operation</b>		<b>SITRANS AS100 Acoustic Sensor</b>	<b>7MH7560-</b>
Operating principle	Acoustic sensing of high frequency emissions caused by impact or friction	An acoustic sensor used for solids flow detection.	<b>0</b>
Typical application	<ul style="list-style-type: none"> <li>• Detects burst filter bags in dust collection systems</li> <li>• Detects material being conveyed in pneumatic conveyor lines</li> <li>• Route confirmation in chute work</li> </ul>	<b>Sensor</b>	<b>1</b>
		Standard temperature range [-20 ... +80 °C (-4 ... +176 °F)] <sup>1)</sup>	<b>3</b>
		Extended temperature range [-40 ... +125 °C (-40 ... +257 °F)] <sup>2)</sup>	<b>4</b>
		Extended temperature range [-30 ... +120 °C (-22 ... +248 °F)] <sup>3)</sup>	
		<b>Cable Length</b>	<b>A</b>
		4 meters (13.12 ft)	
		<b>Sensor Mounting</b>	<b>A</b>
		None	<b>B</b>
		Mounting disk	<b>C</b>
		Mounting tab	
<b>Model</b>		<b>Approvals</b>	
Standard	Standard operating temperature range	CE, C-TICK	<b>1</b>
Extended	Extended operating temperature range	CE, C-TICK, CSA/FM Class II Div. 1, Group E, F and G (includes ½" NPT female fitting)	<b>3</b>
		CE, C-TICK, CSA Class II, Div. 1, Group E, F and G (includes ½" NPT female fitting)	<b>4</b>
		CE, C-TICK, FM/CSA Class II, Div. 1, Group E, F and G, ATEX II 3D (includes M20 female fitting)	<b>5</b>
<b>Operation</b>			
Relative sensitivity	0.5 %/°C of reading, average over the operating range		
Outputs	Analog, 0.08 ... 10 V DC nominal, 100 kΩ minimum load impedance		
<b>Rated operating conditions</b>			
Amb. temperature for enclosure			
• Standard	-20 ... +80 °C (-4 ... +176 °F)	1) Available with approval options 1, 3 and 5 only	
• Extended	<ul style="list-style-type: none"> <li>• -40 ... +125 °C (-40 ... +257 °F) (CE only)</li> <li>• -30 ... +120 °C (-22 ... +248 °F) option</li> </ul>	2) Available with approval option 1 only	
		3) Available with approval option 4 only	
<b>Design</b>		<b>Selection and Ordering data</b>	<b>Order code</b>
Weight	0.4 kg (1 lb)	<b>Further designs</b>	
Enclosure	Enclosure: 304 (1.4301) stainless steel [303 stainless steel (1.4305) on Class II version]	Please add "-Z" to Order No. and specify Order code(s).	
Degree of protection	IP68 (waterproof)	Manufacturer's test certificate M to DIN 55 350, Part 18 and to ISO 9000	<b>C11</b>
Cable		Acrylic coated, stainless steel tag [13 x 45 mm (0.5 x 1.75")]: Measuring-point number/identification (max. 16 characters), specify in plain text	<b>Y17</b>
• Standard	4 m (13 ft) cable, PVC jacketed, 3 twisted pairs, 24 AWG (0.25 mm <sup>2</sup> ), shielded	<b>Operating Instructions</b>	<b>Order No.</b>
• Extended	4 m (13 ft) cable, thermoplastic elastomer jacketed, 6 conductor, 24 AWG (0.25 mm <sup>2</sup> ) conductor, shielded	English	<b>7ML1998-5DM02</b>
		German	<b>7ML1998-5DM32</b>
		French	<b>7ML1998-5DM12</b>
		Spanish	<b>7ML1998-5DM21</b>
		Note: The operating instructions should be ordered as a separate item on the order.	
<b>Power supply</b>	20 ... 30 V DC, 18 mA (typical)	This device is shipped with the Siemens Milltronics manual CD containing ATEX Quick Starts and operating instructions.	
<b>Certificates and approvals</b>	CE, C-TICK, CSA/FM Class II, Div. 1, Group E, F and G (optional) ATEX II 3D (optional)	<b>Spare Parts</b>	
		Mounting tab	<b>7MH7723-1AA</b>
		Mounting disk	<b>7MH7723-1AB</b>
		½" NPT adapter kit for standard temperature range sensor, not Class II approved	<b>7MH7723-1BW</b>
		M20 adapter kit for standard temperature range sensor, not Class II or ATEX approved	<b>7MH7723-1BV</b>
		½" NPT adapter kit for extended temperature range sensor, not Class II approved	<b>7MH7723-1BX</b>
		Note: Adapter kits are not CSA Class II approved	

































